

NOVEDAD



B400STS

Luz estroboscópica de 15 joules.

Muy elevada emisión de luz.
Sincronización automática del flash para una instalación con más de un avisador.
Aplicación interior / exterior IP65.

CÓDIGO	TENSIÓN V	CORRIENTE mA	FRECUENCIA Hz	FRECUENCIA FLASH Hz
B400STS024B/ <input type="checkbox"/>	24 c.c.a.	870	50/60	1
B400STS048B/ <input type="checkbox"/>	48 c.c.a.	480	50/60	1
B400STS115B/ <input type="checkbox"/>	115 c.c.a.	400	50/60	1
B400STS230B/ <input type="checkbox"/>	230 c.c.a.	225	50/60	1

▲ Apliquen el código de color **A** **B** **C** **G** **R** **Y**

Dimensiones (Altura x diámetro): 220mm x 140mm
Construcción: Base: ABS negro
 Tulipa: policarbonato translúcido según normativa UL94V0 f1
Fijación: base, mural, tubo
Prensaestopas: 2 x M20 en la parte lateral del avisador
Terminal: Regleta de conexión
Sección cable: 2,5mm²

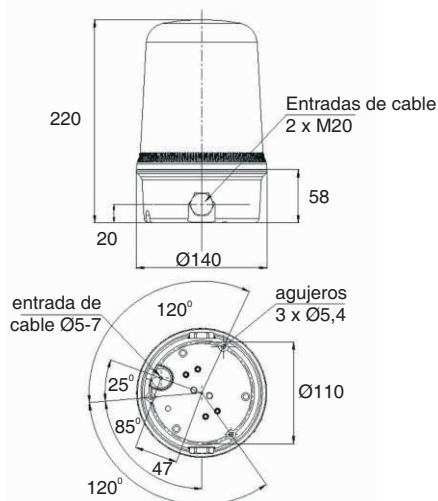

ACCESORIOS:

Soporte mural:

CÓDIGO

B400RAB001



Soporte tubo (145mm):

B400TMA001

